

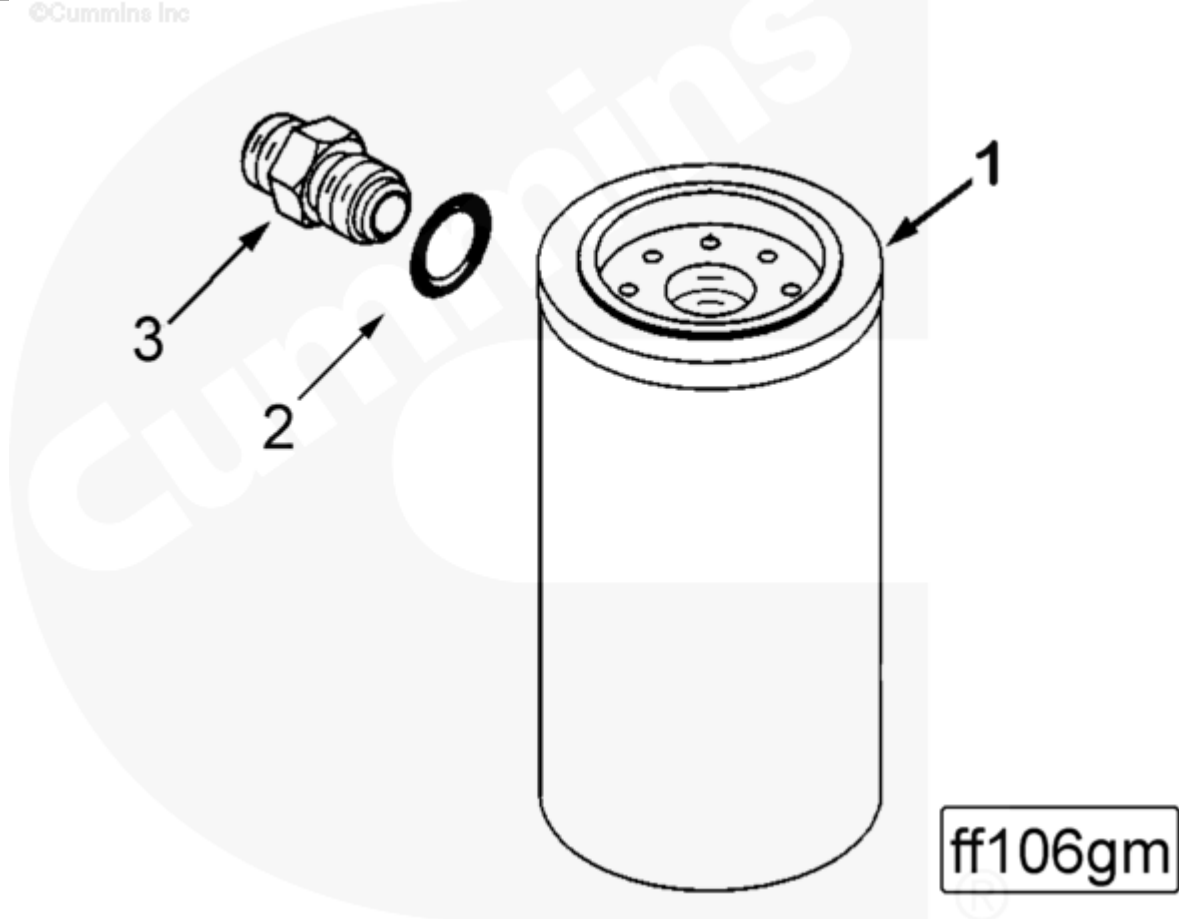

Parts Catalog - Option Detail

| Electronic Parts Catalog - Option Detail | | | | |
|--|--|---------|-----------|-----------|
| Option | Group | Graphic | Film Card | Date |
| FF1245-01 | 06.04 | ff106gm | FF | 05-JUN-00 |
| Engines | G855, G855 CM558, GTA855 CM558 (CM2358) G101, N14 CELECT, N14 CELECT PLUS, N14 MECHANICAL, NH/NT 855, QSM11 CM876 M101, QSM11 CM876 M102M, QSN14 CM876 N103, QSN14 CM876 N105, QSNT14 CM876 N102 | | | |

©Cummins Inc



[SMALL](#) | [MEDIUM](#) | [LARGE](#)

| Cart | Ref No | Part Number | Part Description | Required | Remarks |
|------------------------------|--------|-------------|------------------|----------|------------------------------|
| View My Cart | | | | | |
| | | FF1245-01 | Fuel Filter | | |
| | | | | | Single spin-on fuel/water |
| | | | | | separator mounted on rear of |
| | | | | | fuel pump. |

| | | | | | |
|--------------------------|---|-------------------------|----------------------|---|---------------------------|
| | | | | | Provides straight inlet |
| | | | | | fitting and provision for |
| | | | | | metal drain valve. |
| | 1 | 3331673 | Fuel Water Separator | 1 | |
| <input type="checkbox"/> | | 129866 | Male Union | 1 | |
| <input type="checkbox"/> | 2 | 3040817 | O-Ring Seal | 1 | |
| | 3 | 3100516 | Male Union | 1 | 7/8-14 x 7/8-14 |

© 2019 Cummins Inc., Box 3005, Columbus, IN 47202-3005 U.S.A.
Terms of Use and Disclaimers | Recommended System Requirements
Need Assistance? Please click on the Contact Us button in the top right corner of any page.